





 @AlphaEnergyStorageSystem 
  @AlphaESS 
  @alpha\_ess 
  @AlphaESS 
  www.alpha-ess.com





#### Alpha ESS Co., Ltd.

 +86 513 8060 6891  
 info@alpha-ess.com  
 www.alpha-ess.com  
 JiuHua Road 888, High-Tech Industrial Development  
 Zone 226300 Nantong City, Jiangsu Province





#### Alpha ESS Suzhou Co., Ltd.

 +86 512 6828 7609  
 info@alpha-ess.com  
 www.alpha-ess.com  
 Building 10-A, Canal Town Industrial Park,  
 99 Taihu E Rd, Wuzhong District, Suzhou 215000

#### Alpha ESS Europe GmbH

 +49 610 3459 1601  
 europe@alpha-ess.de  
 www.alpha-ess.de  
 Paul-Ehrlich-Straße 1a 63225 Langen



#### Alpha ESS Australia Pty. Ltd.

 +61 1300 968 933  
 australia@alpha-ess.com  
 www.alpha-ess.com.au  
 Unit 1, 2 Ralph Street Alexandria NSW 2015



#### Alpha ESS Italy S.r.l.

 +39 599 239 50  
 info@alpha-ess.it  
 www.alpha-ess.it  
 Via Loda,17-41013 Castelfranco Emilia(MO)



#### Alpha ESS Korea Co., Ltd

 +82 64 721 2004  
 korea@alpha-ess.com  
 2F, 19-4, Nohyeong 11-gil, Jeju-si, Jeju-do,  
 Republic of Korea

#### Alpha ESS UK Co., Ltd

 uk@alpha-ess.com  
 Drake House, Long Street, Dursley, gl11 4hh

#### Alpha ESS International Pte. Ltd.

 Singapore@alpha-ess.com  
 Blk 55 Ayer Rajah Crescent #01-01, Singapore  
 139949

#### Alpha ESS USA, Inc.

 USA@alpha-ess.com  
 638 S Ahwanee Ter Sunnyvale, California,  
 94085 United States of America

# INSTALLATION MANUAL OF ENERGY STORAGE SYSTEM (ESS)

## STORION-T50/T100 (INDOOR ,WITH M48112-S)



## Copyright Statement

This manual is under the copyright of Alpha ESS Co., Ltd, with all rights reserved. Please keep the manual properly and operate in strict accordance with all safety and operating instructions in this manual. Please do not operate the system before reading through the manual.

# CONTENT

<b>01</b>	<b>INTRODUCTION</b>	<b>01</b>
1.1	Brief Introduction .....	01
1.2	Explanation of Terms .....	01
<b>02</b>	<b>SAFETY INSTRUCTIONS</b>	<b>03</b>
2.1	Keep the Manual .....	03
2.2	Operator Requirements .....	03
2.3	Protection of Warning Sign .....	03
2.4	Setting of Warning Sign for Safety .....	04
2.5	Live Line Measurement .....	04
2.6	Measuring Equipment .....	04
2.7	Electrostatic Prevention .....	04
2.8	Moisture Prevention .....	04
2.9	Operation after Power Failure .....	04
2.10	Minimum Personal Protective Equipment .....	05
<b>03</b>	<b>PRODUCT DESCRIPTION</b>	<b>06</b>
3.1	Appearance of the Product .....	07
3.2	Product Characteristics .....	07
3.3	Parameters of Components .....	08
3.3.1	PCS .....	08
3.3.2	Battery System .....	11
3.3.3	PV Combiner Box (If applicable) .....	16
<b>04</b>	<b>INSTALLATION</b>	<b>20</b>
4.1	Installation Precautions .....	20
4.2	Parts List .....	20
4.3	Installation .....	23
4.3.1	PCS Installation .....	25
4.3.2	Battery System Installation .....	21
4.4	Wiring .....	26
4.4.1	Battery Side Wiring .....	26
4.4.2	Inverter Side Wiring .....	30
4.4.3	AC Auxiliary Power-Wiring .....	33
4.4.4	System grounding .....	33
4.4.5	PV Side-Wiring .....	34
4.4.6	AC Side-Wiring .....	35

4.4.7. Meter Wiring(On-grid mode) .....	37
4.4.8. Connect the communication cable for the generator .....	39

<b>05</b>	<b>START-UP AND OPERATION</b>	<b>41</b>
-----------	-------------------------------	-----------

<b>06</b>	<b>REMOVE THE COMMUNICATION SHORTING SCREW</b>	<b>42</b>
-----------	------------------------------------------------	-----------

<b>07</b>	<b>CONTACT</b>	<b>43</b>
-----------	----------------	-----------

## 01 Introduction

### 1.1 Brief Introduction

This manual applies for Storion-T50/T100 Li-ion battery energy storage system, mainly includes:

#### (1) Safety introduction

Introduces the product use, operating notes and qualification of operators of T50/T100 Li-ion battery energy storage system.

#### (2) Product description

Describes product appearance, product characteristics, system composition and major functions of T50/T100 Li-ion battery energy storage system.

#### (3) System installation

Introduces the installation of T50/T100, including precautions.

### 1.2 Explanation of Terms

#### (1) Lithium iron phosphate cell (LiFePO<sub>4</sub>)

Basic unit constituted by electric poles and electrolytes; each cell is independent and closed.



**NOTE:** Paralleled cell cannot be regarded as an independent cell, even repacked as one whole battery pack.

#### (2) Lithium iron phosphate pack

The pack is made up of battery monitoring circuit, battery equalization circuit, electrical connectors, communication interfaces, thermal management devices and multiple Lithium iron phosphate cells.



**NOTE:** For packs from same company, all the details such as physical size, working performance and interface specification should be consistent so that all the packs are compatible and interchangeable.

#### (3) Battery management system

Electronic equipment collection for monitoring the operating information of cells, packs and system units (such as voltage, current, temperature, protective parameter of batteries), evaluating the state of charge (SOC), the state of health (SOH) and cumulative processed energy and protecting batteries for safety, etc.

#### (4) Battery system unit

Batteries connected in series/parallel in the pack with a battery management system (BMS) in which accesses to DC side of a bidirectional converter

#### (5) Storage unit

A combination of a bidirectional converter and a battery system unit, which can be used as an independent load or be controlled directly by monitoring system.

### 2.1 Keep the Manual

This manual contains important information about operating the system. Before operating, please read it very carefully.

The PCS should be operated in strict accordance with the description in the manual, in case of the damage or loss to equipment, personnel and property.

This manual should be kept carefully for maintenance and repairation.



**NOTE:** To ensure optimal reliability and to meet warranty requirements, the Energy Storage System must be installed according to the instructions in this manual.

### 2.2 Operator Requirements

The operators should get a professional qualification, or be trained by qualified person.

The operators should be familiar with the whole storage system, including compositions and working principles of the system.

The operators should be familiar with the Product Instruction.

While carrying out maintenance work it has to be at least two operators in the field all the time. They can't operate on any equipment until they are all powered off and fully discharged.

It is strictly prohibited for any maintenance operation when equipment is on or charged.



**NOTE:**

- (1) If the installer leaves the site, but the system during debugging should be shut down in time, including batteries and PCS.
- (2) When the system fails, please refer to the troubleshooting table to solve the problem first. If the problem cannot be solved, please contact AlphaESS engineers. If you cannot contact the engineers in time, please shut down the system.

If the equipment is damaged due to unauthorized operation or without following the above precautions, it will not be covered by the warranty.

### 2.3 Protection of Warning Sign

The warning sign contains important information for the system to operate safely and it is strictly prohibited to be torn or damaged.

Ensure that the warning sign is always clear.

The signs should be replaced immediately if damaged.



## 2.4 Setting of Warning Sign for Safety

To prevent erroneous operations and accidents caused by unrelated personnel nearby, the suggestions below should be followed during the instruction, maintenance and repairing:

Obvious signs should be set at the front and rear-level switch in case of accidents caused by false switching.

Warning signs or tapes should be set near the operation areas.

Keys of the system must be pulled out after maintenance or operation.

## 2.5 Live Line Measurement

High voltage in the container. Touching by accident may cause vital electric shock.

Equipment protection must be taken when do live line measurements (e.g. insulation gloves).

The measuring equipment should be connected and used correctly to ensure personnel safety. When measuring, at least two workers are needed.

## 2.6 Measuring Equipment

Ensure the electrical parameters to match requirements, and related measuring equipment are required when the system is being connected or tested.

Ensure the connection and operation to match the specification in case of electric arc or shock.

## 2.7 Electrostatic Prevention

Contact or improper operation of the printed circuit board or other ESD sensitive components may result in damage to the device. Unnecessary contact should be avoided.

## 2.8 Moisture Prevention

It is very likely that moisture may cause damages to the system.

Do not open the container door if the humidity is higher than 95%.

Repairing or maintaining activities in wet conditions should be avoided or limited.

## 2.9 Operation after Power Failure

The battery system belongs to energy storage system, which maintains fatal high voltage even when the DC side is disconnected. Therefore, touching of the battery output is strictly prohibited.

The PCS maintains fatal voltage even when both the DC or AC side are disconnected, so it must be tested by the multimeter for safety before operation.

## 2.10 Minimum Personal Protective Equipment

For the safety of operators to the system, personal protective equipment are required. During the operation, following protective equipment are required:

No.	Item	Notes
1	Work clothes	
2	Protective shoes	
3	Protective glasses	

When doing maintenance works such as checking cables or wires, measuring voltage, replacing small electrical parts or cleaning modules and brackets, as minimum the following protective equipment are required:

No.	Item	Notes
1	Work clothes	
2	Protective shoes	
3	Protective glasses	
4	Insulated gloves	For touching live parts



**NOTE:** All metal tools during maintenance should be insulated.

When replacing modules, the following protective equipment are required:

No.	Item	Notes
1	Work clothes	
2	Protective shoes	
3	Protective glasses	
4	Insulated gloves	For touching live parts



**NOTE:** When replacing modules, the hydraulic lift should be used carefully in case that the modules may fall down. All workmen are suggested to wear high-safety and high strength protective shoes to protect their feet.

03 Product Description

The AlphaESS Storion-T50/T100 energy storage system supports on-grid mode and off-grid mode.

The overall system connection diagram is as follows:

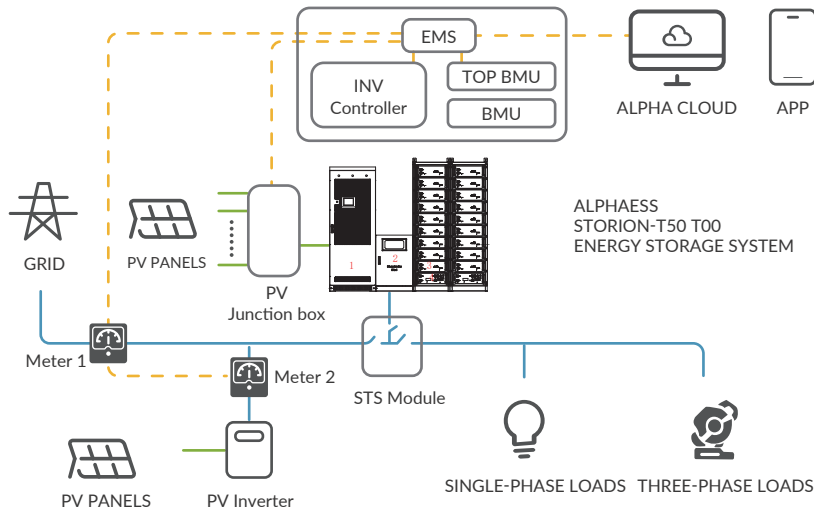

Figure 3-1 Application of the system, on-grid mode

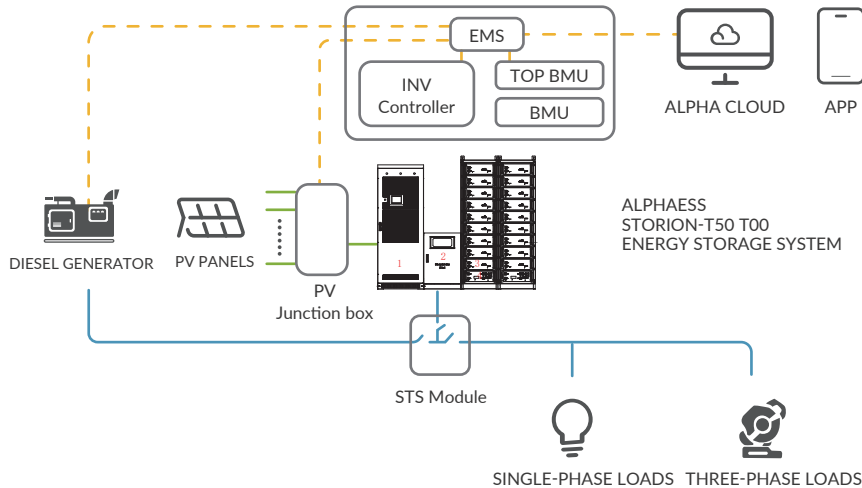

Figure 3-2 Applications of the system, off-grid mode

3.1 Appearance of the Product

Figure 3-3 shows the appearance of the system.

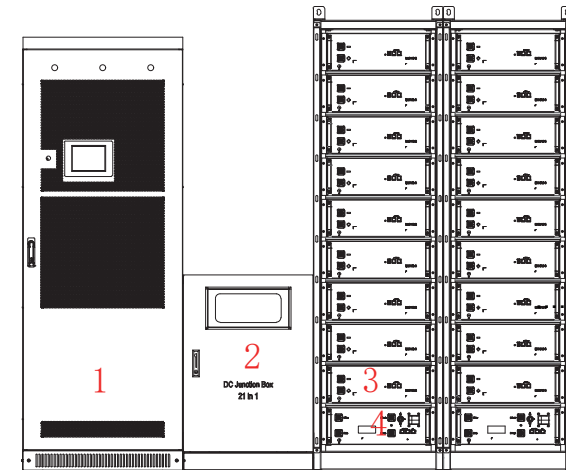

Figure 3-3 T50/T100 without container

Table 1 T50/100 System composition

Item	Components
1	Storion-T50/100-INV
2	Junction Box (With TOP BMU Box)
3	M48112-S
4	HV900112

3.2 Product Characteristics

LiFePO4 batteries produced by AlphaESS have longer lifespan and higher reliability, which is able to satisfy the application of energy storage systems.

The system is highly modular designed, and it is easier to assemble, transport and maintain.

The system has a three-level BMS and is allowed for system expansion.

The system adopts full-time equalization technology, which can ensure the consistency of battery and module.

The system is designed as a removable container which is compact, flexible, easy for installation and testing, suitable for the working environment and is available for different kinds of applications.

The system has current balance technology between strings in case of circulating current or unbalanced power.

The system has relatively developed thermal management technology so that the consistency of the system environment can be guaranteed.

The system has both remote monitor function and local control function.

The system realizes flexible scheduling of electric power system through communication among BMS, PCS and monitoring system.

The system realizes emergency fire protection by using the automatic alarming and fire extinguishing system

### 3.3 Parameters of Components

#### 3.3.1. PCS

##### 3.3.1.1 Product Instruction

Storion-T50/T100-INV is a hybrid inverter. It has DC/DC and DC/AC modules. It can transform the DC electricity from PV panels into three-phase AC electricity to supply loads. The DC/DC module can charge batteries by using the electricity generated by PV panels. The DC/AC module is bidirectional so that the battery can also be charged by the grid through the inverter.

##### 3.3.1.2 Appearance Instruction

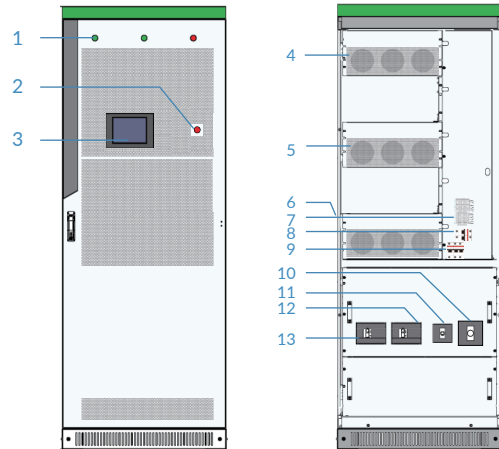

Figure 3-4 Appearance of the PCS

Table 2 Composition of the PCS

Item	Description	Description
1	Indicator lights	
2	EPO (Emergency Power Off)	
3	Touch Screen	
4	PCS-DC (1~2 module(s))	50KW 1 set; 100KW 2 sets
5	PCS-AC (1~2 module(s))	50KW 1 set; 100KW 2 sets
6	STS module	Switching device; Only for the models with STS
7	Wiring Terminal	Digital Input and Digital Output
8	AUX power supply switch	
9	SPD switch	
10	AC breaker (Grid)	
11	AC breaker (Load)	
12	Battery switch	
13	PV switch	



**NOTE:** Components 7 Wiring Terminal, 8 AUX power supply switch, 9 SPD switch can be seen after unfold the baffle.

##### 3.3.1.3 Technical Parameters

Table 3 Technical parameters of the PCS

No.	Item	Storion-T50-INV	Storion-T100-INV
<b>AC Side Data (off-grid)</b>			
1	AC Nominal Output Power	50 kW	100 kW
2	AC Max. Power	55 kW	110 kW
3	AC Output Voltage	400 V (± 10% configurable)	
4	AC Output Current	72 A (max. 79 A)	144 A (max. 159 A)
5	AC Connection	3-phase and 4-wire system (including transformer)	
6	AC Frequency	50 Hz / 60 Hz	
7	Output THDU	< 2 %	

No.	Item	Storion-T50-INV	Storion-T100-INV
<b>AC Side Data (off-grid)</b>			
8	AC PF	Listed: 0.8~1 leading or lagging (Load-depend)	
		Actual: 0.1~1 leading or lagging (Load-depend)	
9	Overload Capability	100%~110% long-term; 110%~120% 1min; 120%~150% 200ms;	
<b>DC Data (Battery Side)</b>			
10	DC Voltage Range	250 ~ 520 V	
11	One-Way Maximum Input Current	150 A	300 A
12	Max. DC Power	50 kW	100 kW
<b>PV Side Data</b>			
13	PV Voltage Range	520 ~ 900 V (MPPT: 520~800 V)	
14	PV DC Max. Current (in case of completely consumption)	192 A	384 A
15	Max. PV Power	100 kW	200 kW
<b>General Data</b>			
16	Max Efficiency	95.5%	
17	Dimensions (W x H x L)	800 x 2160 x 800 mm	
18	Weight	520 kg	750 kg
18	Altitude	3000 m	
20	Ingress Protection	IP20	
21	Noise	70 dB	
22	Operation Temperature	-25 °C ~ +50 °C (De-rating over 45°C)	
23	Cooling Concept	Forced Air	
24	Humidity	0~95% (Non-Condensing)	
25	Communication Interfaces	Ethernet, RS-485, CAN	

### 3.3.1.4 Emergency Stop Switch

The PCS stops working immediately after pushing the button.

If you want to restart the converter, please follow the process below:

- A. Conduct clockwise rotation on the emergency stop switch and then loosen the locking status.
- B. Push the AC breaker into "OFF" position, then turn the AC breaker "ON" .
- C. Launch the machine and operate it as required

### 3.3.2. Battery System

Table 4 Battery system parameters

Item	Description	Parameter	Remark
1	Nominal discharge power	28 kW ~ 50 kW / 100 kW	
2	Energy storage capacity	According to the project situation	Ambient temperature is 30°C, measured at DC side
3	Continuous discharge current	1C (continuous)	
4	Direct voltage	250 ~ 520 V	
5	Communication interface	RS485, CAN2.0	

#### 3.3.2.1 M48112-S

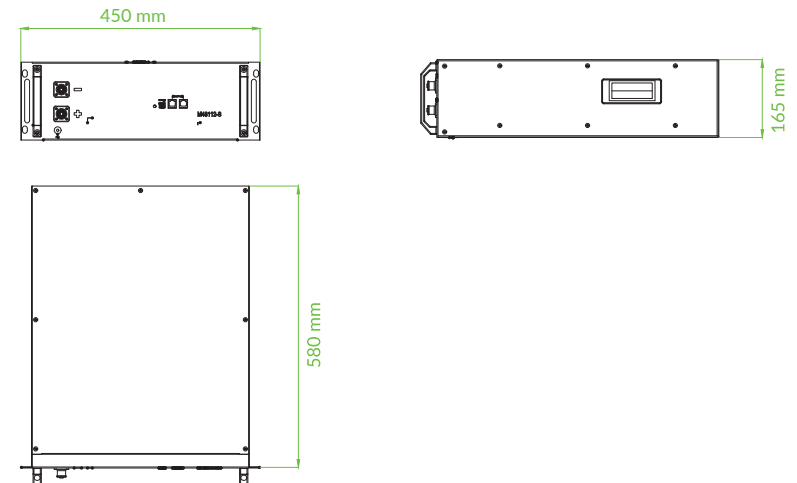

Figure 3-5 M48112-S appearance and dimensions

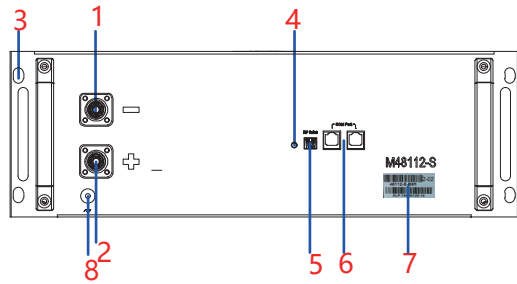

Figure 3-6 M48112-S front view

Table 5 Battery interface definition:

No.	Description	No.	Description
1	Battery negative pole	5	Dip switch
2	Battery positive pole	6	COM port (CAN) x 2
3	grounding point x 4	7	Information label
4	LED light	8	Grounding point (reserved)

The dip switch of M48112-S defines the serial number. Please see the detailed description in the following table.

Table 6 Dip switch definition of M48112-S

Serial Number	Dip Switch	Serial Number	Dip Switch	Serial Number	Dip Switch
1		6		11	
2		7		12	
3		8		13	
4		9		14	
5		10		15	

Table 7 Battery technical parameters:

No.	Item	Technical parameter	Remark
1	Battery model	M48112-S	
2	Assembly method	16S2P	
3	Nominal voltage	51.2 V	
4	Voltage range	48 ~ 57.6 V	
5	Nominal capacity	112 Ah	Max. charge / discharge current 1C
6	Nominal stored energy	5.734 kWh	
7	Work power consumption	0.4752 W	
8	Dormant power consumption	1.52 mW	Battery dormant state
9	Max. charge/discharge current	112 A	Constant current mode
10	DC internal resistance	< 20 mΩ	Factory default
11	Transportation/storage temperature range	-20 ~ 45 °C	
12	Operating temperature range	-10°C ~ 50 °C	
13	Communication mode	CAN	
14	Weight	65 kg	
15	Size (W x D x H)	450 x 580 x 165 mm	
16	Humidity	15% ~ 85%	

3.3.2.2 HV900112

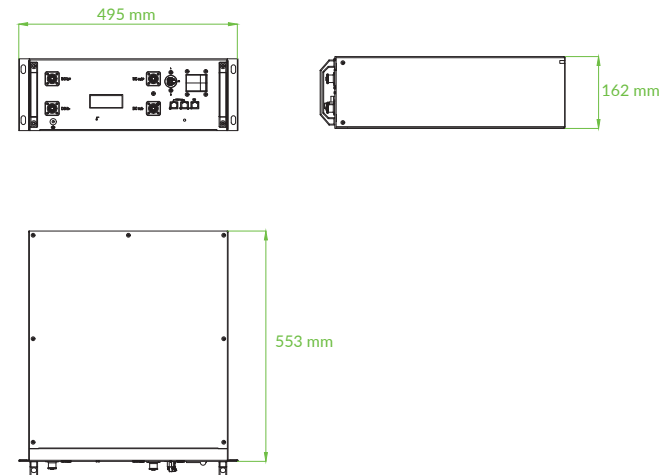

Figure 3-7 HV900112 appearance and dimensions

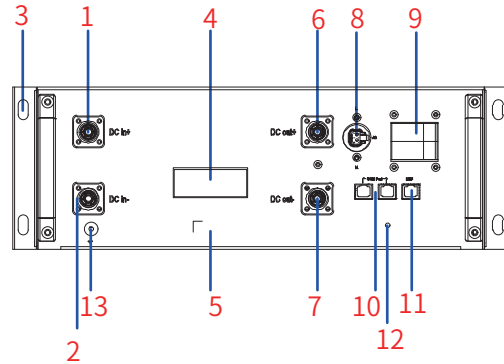

Figure 3-8 HV900112 front view

Table 8 HV900112 interface definition:

No.	Description	No.	Description
1	DC in+	7	DC out-
2	DC in-	8	AC input (auxiliary power)
3	grounding point x 4	9	AC Air switch (auxiliary power)
4	Moulded case circuit breaker	10	BMU COM port (CAN) x 2
5	Information label	11	LMU COM port (CAN)
6	DC out+	12	LED light
		13	Grounding point (reserved)

Table 9 HV900112 technical parameters:

No.	Item	Technical parameter	Remark
1	High-voltage control box	HV900112	
2	Working voltage range	200 ~ 900 V	
3	Modules Connection	5 ~ 9 M48112-S in series	for T50/100, with only 5 batteries, the batteries will not be fully discharged
4	Rated current	112 A	
5	Dimensions (W x D x H)	495 x 553 x 162mm	
6	Weight	20 kg	
7	Power consumption	<10 W	
8	Color	Black	

### 3.3.2.3 Top BMU Box (with EMS)

Functions such as remote monitoring, remote upgrade, etc. can be realized through the TOP BMU Box with EMS.

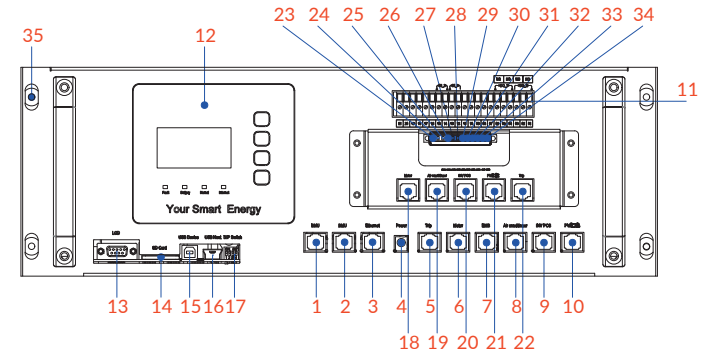

Figure 3-9 Front view of TOP BMU box with EMS

Table 10 Top BMU box with EMS interface definition

No.	Description	No.	Description
1	BMU COM port	18	Meter COM port (Used to switch the external communication RJ45 port to RS485 port)
2	BMU COM port	19	Air conditioner COM port(Used to switch the external communication RJ45 port to RS485 port)
3	Ethernet	20	INV PCS COM port (Used to switch the external communication RJ45 port to RS485 port)
4	Reserve power supply	21	PV junction COM port (Used to switch the external communication RJ45 port to RS485 port)
5	Trip COM port	22	Dry contact COM port (Used to switch the external communication RJ45 port to RS485 port)
6	Meter COM port	23	Reserved
7	EMS COM port (reserved for external device communication with BMU)	24	Reserved
8	Air conditioner COM port	25	Meter RS485A port
9	PCS COM port	26	Meter RS485B port

No.	Description	No.	Description
10	PV junction COM port	27	Air conditioner RS485A port
11	Dry contact port	28	Air conditioner RS485B port
12	EMS display screen	29	PCS RS485A port
13	Burning port	30	PCS RS485B port
14	Storage card	31	PV Junction RS485A port
15	Reserved	32	PV Junction RS485B port
16	Reserved	33	Reserved
17	DIP switch	34	Reserved
		35	Grounding point x 4



**NOTE:** TOP BMU box (with EMS) can communicate with outside device, such as PCS, Air conditioner, PV junction box, etc. You can connect it from the COM port (from Port 1 to 10) in TOP BMU box to the device by using regular net cables. If the communication type is RS485, please connect it to the RS485A and RS485B port in TOP BMU box. Besides, the two corresponding COM ports in TOP BMU box should be connected with each other.

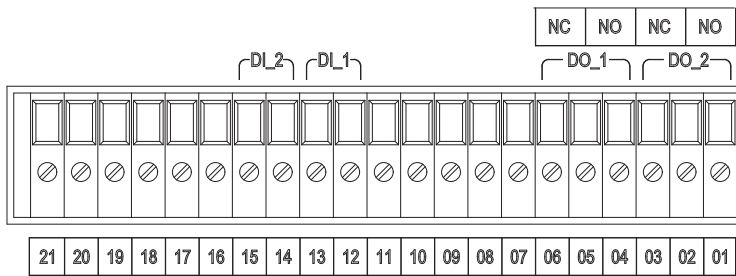

Figure 3-10 Dry contact of TOP BMU

Table 11 Dry contact description

No.	Description	No.	Description
1	Dry contact of generator	12	Dry contact of Fire controller fault
2		13	Dry contact of Fire controller fault
3	Reserved	14	Dry contact of Fire alarm
4		15	Dry contact of Fire alarm

No.	Description	No.	Description
5	Dry contact of BMS fault	16	Reserved
6		17	
7	18		
8	19		
9	20		
10	21		
11			

Table 12 Technical parameters:

No.	Item	Technical parameter
1	Dimensions(W x D x H)	490.6 x 323 x 161 mm
2	COM	RS-485×4; Ethernet 10/100/1000Mbps×1
3	Internal storage	Micro SD card, 16 GB
4	Events diary	Recent 5 years happenings
5	Work voltage	24 V
6	Power consumption	<10 W

3.3.2.4 Junction box

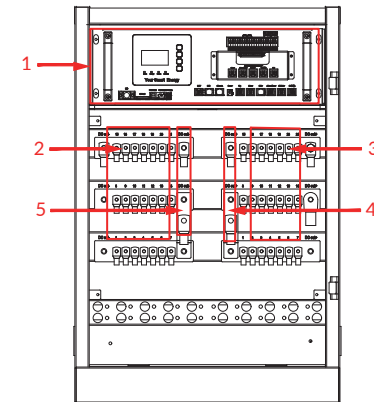

Figure 3-11 Inside of the junction box

**Table 13 Wiring definition of the junction box:**

No.	Description	No.	Description
1	TOP BMU Box	4	1 x DC OUT INV+
2	21 x DC IN BAT-	5	1 x DC OUT INV-
3	21 x DC IN BAT+		

**Table 14 Technical parameters:**

No.	Description	Technical parameter
1	Dimensions (W x D x H)	564 x 439 x 845 mm
2	Weight	50 kg
3	Max voltage	1000 V
4	Max current	300 A
5	Color	Black(With M48112-S);

**3.3.2.5 Battery Rack**

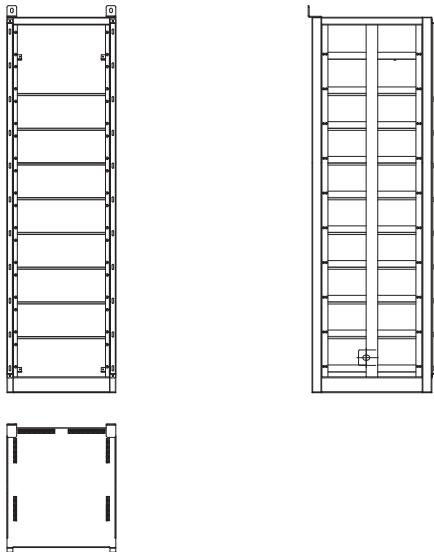
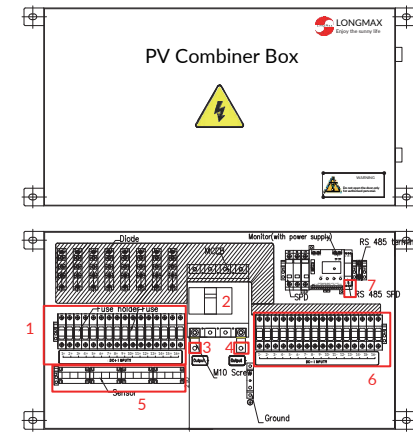

**Figure 3-12 Battery Rack**

**Table 15 Technical parameters:**

No.	Description	Parameter
1	Dimension(W x D x H)	564 x 667.5 x 2006 mm
2	Weight	120kg
3	Color	Black

**3.3.3 PV Combiner Box (If applicable)**



**Figure 3-13 PV Combiner box**

**Table 16 Wiring definition of the combiner box:**

No.	Description	No.	Description
1	PV IN +	5	HALL Sensor
2	Moulded Case Circuit Breaker	6	PV IN -
3	DC OUT+	7	RS485
4	DC OUT-		



**4.1 Installation Precautions**

The following sites are not allowed for installation:







- A.Sites which are salty and where humid air can penetrate.
- B.Flooded areas.
- C.Earthquake areas (additional security measures are required here) .
- D.Sites that are higher than 3000 meters above the sea level.
- E.Sites that are in an explosive or potentially explosive atmosphere.
- F.Sites with extreme changes of ambient temperature.
- G.Sites with highly flammable materials or gases.





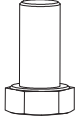

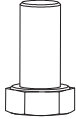



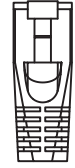
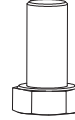

**NOTE:** The indoor temperature of the installation system is preferably between 15°C ~25 °C.

**4.2 Parts List**

**Table 17 Parts List**

M48112-S			
			
810.10515-00 1 X Power Cable 130 mm, Black - Red, BAT - BAT	810.00033-00 1 X Communication Cable 280 mm, BAT - BAT	410.00080-00 4 x M6*16	411.00026-00 4 x M6 Grounding Serrated Washer
HV900112			
			
810.00048-00 1 X Communication Cable 680 mm, HV Box - HV Box	410.00080-00 4 X M6*16	410.50001-00 4 X M6 Grounding Serrated Washer	810.10553-00 AC Auxiliary Power Cable 7000 mm

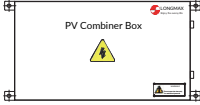
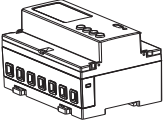
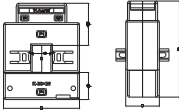
			
810.90006-00 1 X Power Cable 2500 mm, Black - Black, BAT - HV	810.90004-00 1 X Power Cable 130 mm, Red - Red, BAT - HV		
DC Junction box (With TOP BMU Box)			
			
810.00058-00 1 X Communication Cable 2500 mm, TOP BMU - HV	810.10412-00 1 X Terminal Resistance	410.00080-00 4 X M6*16	411.00026-00 4 X M6 Grounding Serrated Washer
			
810.10644-00 1system: 1 x 4500 mm, 50mm2 Power Cable, Black-Black, For Junction box- INV (T50) ; 810.11000-00 1system: 1 x 4500 mm, 95mm2 Power Cable, Black-Black, For Junction box - INV(T100)	810.10643-00 1 system: 1 x 4500 mm, 50mm2 Power Cable, Red-Red, For Junction box - INV(T50); 810.10999-00 1 system: 1 x 4500 mm, 95mm2 Power Cable, Red-Red, For Junction box - INV(T100);	810.10611-00 2 cluster: 1 x Commu- nication Cable 7500 mm EMS - INV	

Battery Rack			
			
810.90017-00 1 cluster: 1 X 4500 mm, 35mm <sup>2</sup> Power Cable, Black-Black, For HV Box - Junction box	810.90016-00 1 cluster: 1 X 4500 mm, 35mm <sup>2</sup> Power Cable, Red-Red, For HV Box - Junction box		
System			
			
PV Combiner box (If applicable)	1 x Meter with 3 CT (on-grid mode-DC); 2 x Meter with 6 CT (on-grid mode -AC/Hybrid)	3*CT (on-grid mode-DC); 6*CT (on-grid mode -AC/Hybrid) Outline size (W*H*D) :90*14*40mm Through size (a*e) :20*30mm	1 X Installation manual
			
1 X Operation and maintenance manual			

### 4.3 Installation

#### 4.3.1. PCS Installation

##### 4.3.1.1 Removal

When removing the T50/T100-INV, a forklift can be used to remove the whole case. Users can lift the device bottom with a forklift or remove the inverter cabinet through the lifting hole on its top with a crane. It can be transported alone.

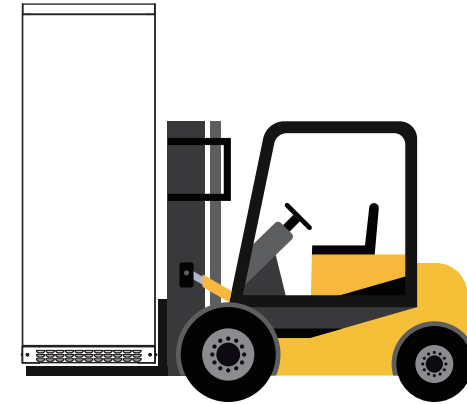

Figure 4-1 Moving method for inverter

##### 4.3.1.2 Operation Space

During the installation of the PCS, a proper distance from its peripheral walls to the door should be kept as to ensure that the machine door can be opened and closed conveniently and there will be sufficient space for module insertion and extraction, normal heat dissipation and user' soperation.

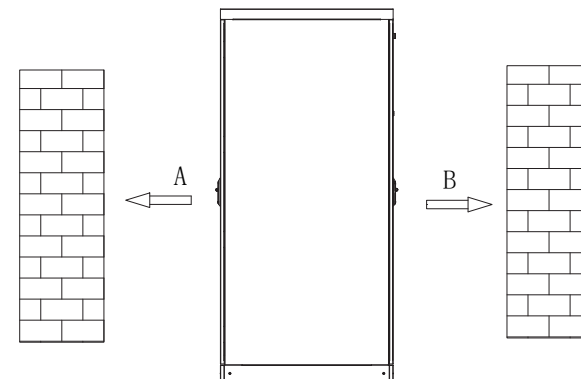

Figure 4-2 Installation space

A≥1,000mm, make sure that the front door of the cabinet can be fully opened and there is sufficient space for ventilation. Users can conveniently insert and extract the module and operate the breaker.

B≥1,000mm, make sure that the rear door of the cabinet can be fully opened. Ventilation and heat dissipation should be guaranteed. Users can also have sufficient space for product maintenance.

### 4.3.1.3 Cabinet Installation

After the cabinet is removed to the installation position with a forklift or a tool. The cabinet should be adjusted and removed to the designed position. Then open the internal door of cabinet, and fix the cabinet with M13 screws, as shown in Figure 4-3.

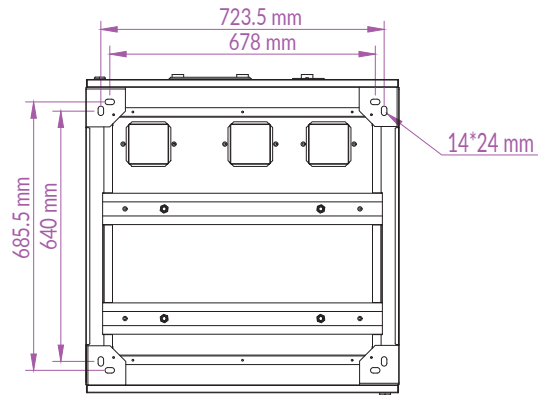

Figure 4-3 Diagram of the cabinet base

When the cabinet needs to be fixed on the steel channel, Φ14 holes can be made in the steel channel. Fix the cabinet to the steel channel with screws, as shown in Figure 4-4.

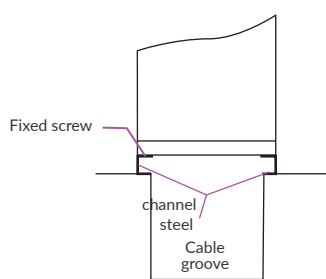

Figure 4-4 Fix the cabinet to the steel channel

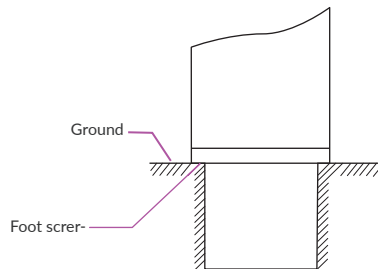

Figure 4-5 Fix the cabinet to the concrete floor

When the cabinet is fixed to the concrete floor, make holes on the floor and fix the cabinet to the concrete floor with expansion screws, as is shown in Figure 4-5.

### 4.3.2. Battery System Installation

#### 4.3.2.1 Battery Rack Installation

That depends on the customer

#### 4.3.2.2 Battery Installation

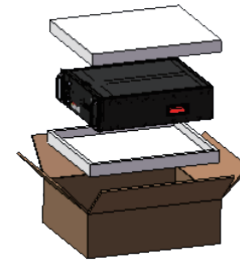

Figure 4-6 Remove the battery

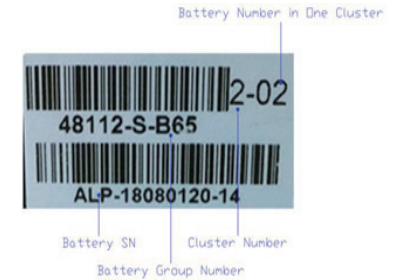

Figure 4-7 Battery label information

**Step 1:**

Open all the battery packages.

**Step 2:**

Check the Battery No. and cluster No. on the battery cover.

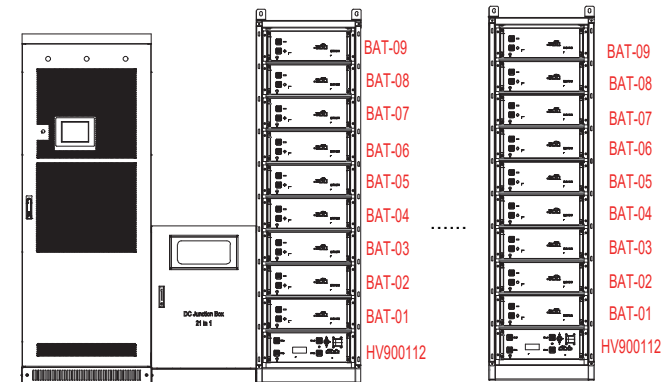

Figure 4-8 Installation the battery

**Step 3:** Put the same cluster of batteries on the same rack with the serial number of 01 to 09 from top to bottom as the above figure shows. The dip switch defines the serial number, see Table 6.

**NOTE :** All the cluster battery group No. shall be the same. In one cluster the dip switch of each battery should be different from others. When you are installing the battery, please to avoid scratches because of the heavy battery.

**Step 4:** After completing one rack, please check whether the installed batteries have the same cluster No. and the same battery group No.

### 4.4 Wiring

#### 4.4.1. Battery Side Wiring

##### 4.4.1.1 Communication Cables Connection

**A.** Please refer to the following figure, connect the communication cables among batteries of each cluster. These cables are in each battery parts list.

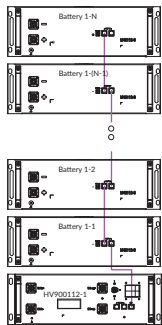

Figure 4-9 Communication cables connection in one cluster

**B.** Take the terminal resistance in the HV900112 parts list and insert it into the top battery COM port of each battery cluster. You can see the detailed information in Figure 4-10.

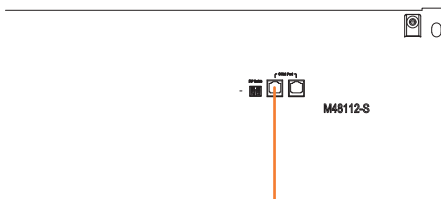

Figure 4-10 Terminal resistance in the top battery of each cluster

- C.** Connect the bottom battery (COM Port) to HV900112 (LMU Port) by using the communication cables from HV900112 parts list. Please see Figure 4-11
- D.** Connect HV900112 (COM Port) to TOP BMU box (COM Port, Port 1 or 2) by using the communication cable from TOP BMU part list. Please see Figure 4-11.

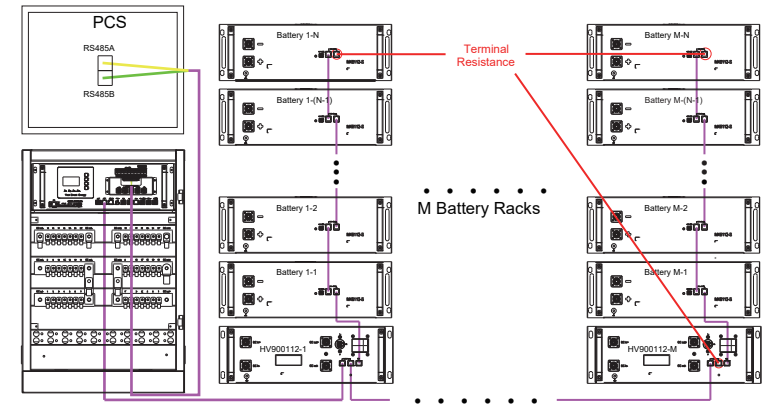

Figure 4-11 Battery side communication cables connection

E.  
Connect the PCS and EMS after opening the PCS cabinet front door and removing the panel of the right side. You can see the communication interface at the right bottom. Then please connect TOP BMU box (Port 29 -485A and Port 30 - 485B) to the PCS (Port 9 - 485A and Port 10 - 485B ) by using the RS485 cable from the parts list , and connect TOP BMU box dry contact port (Port 05 and Port 06) to the PCS (Port 1 and Port 2 ) by using the RS485 cable from the parts list as Figure 4-12 shows.

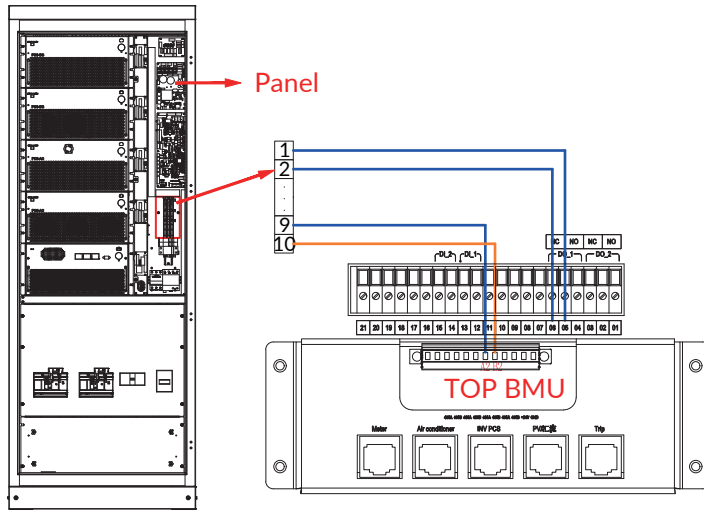

Figure 4-12 Connection between EMS and PCS

The terminal strip ports of PCS are defined as is shown in Table 18.

Table 18 Definition of terminal strip ports of PCS

Item	Terminal	Notes
Input Signal Loop		
1	IN1	BMS Fault Signal
2	IN1 GND	
3	IN4	On/Off-grid Switch Node 1
4	IN4 GND	
5	IN5	On/Off-grid Switch Node 2
6	IN5 GND	
External Communication Loop		
7	CAN H	From External BMS
8	CAN L	
9	485 A	To External RS485
10	485 B	
External EPO Input		
11	EPO-C	From External EPO
12	EPO-NO	

F

Connect the COM port 9 and COM port 10 of TOP BMU box with a regular net cable.

G

Another COM port of HV900112 should be inserted with the terminal residue from DC Junction box parts list. Please see the detailed information Figure 4-13.

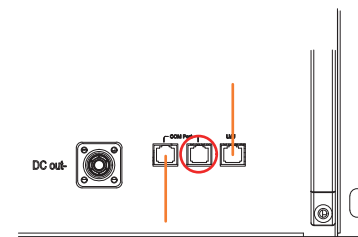

Figure 4-13 Terminal resistance in one of the HV900112

**H.**  
Connect TOP BMU COM port 3 to Ethernet.

**4.4.1.2 Battery Power Cables Connection**

The battery DC positive and negative port of HV900112 can be directly connected to the BAT+ and BAT- of PCS as Figure 4-14 shows.

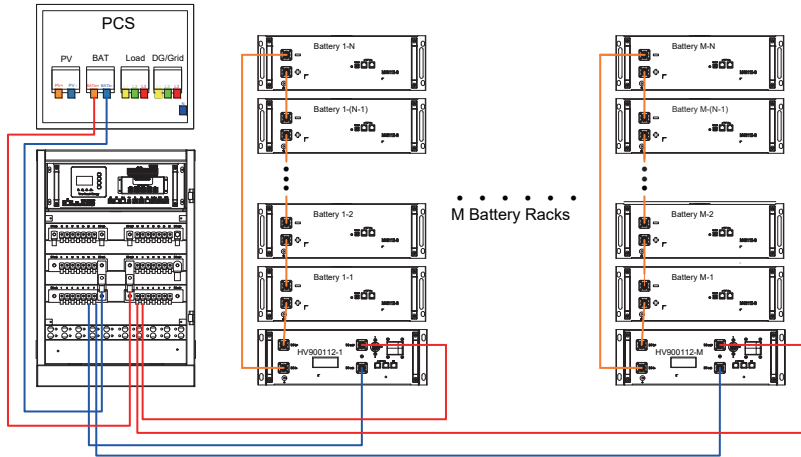
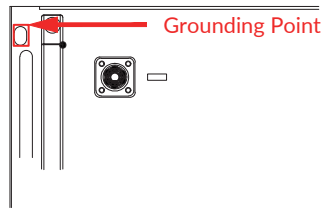

Figure 4-14 Battery side power cables connection



After wiring the battery, please fix each box with the four screws and four grounding serrated washers to the racks. These screws and grounding serrated washers are shipped in the corresponding batteries, HV900112, Top BMU box.

Figure 4-15 Grounding Point

**4.4.2. Inverter Side Wiring**

The inlet and outlet wiring holes located in bottom of the PCS cabinet. The cables put into the cable channel via the wiring holes at the base. The cooper bars for wiring can be seen after opening the front door and dismantling the dam-board. As for wiring requirements, single cables or multiple cables with proper wire diameter should be selected.

The wiring should be in accordance with the National Electrical Code or other local standards.

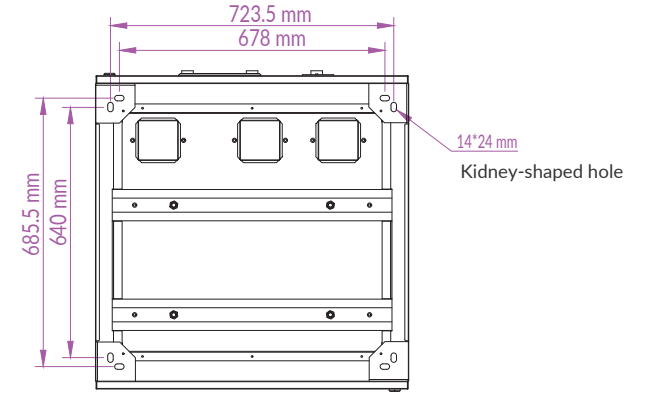

Figure 4-16 PCS rack wiring hole and corresponding copper bars

Open the dam-board beside the switch and then the wiring copper bar can be seen as Figure 4-17 shows.

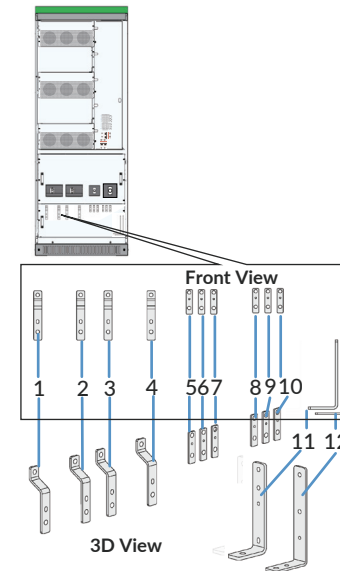
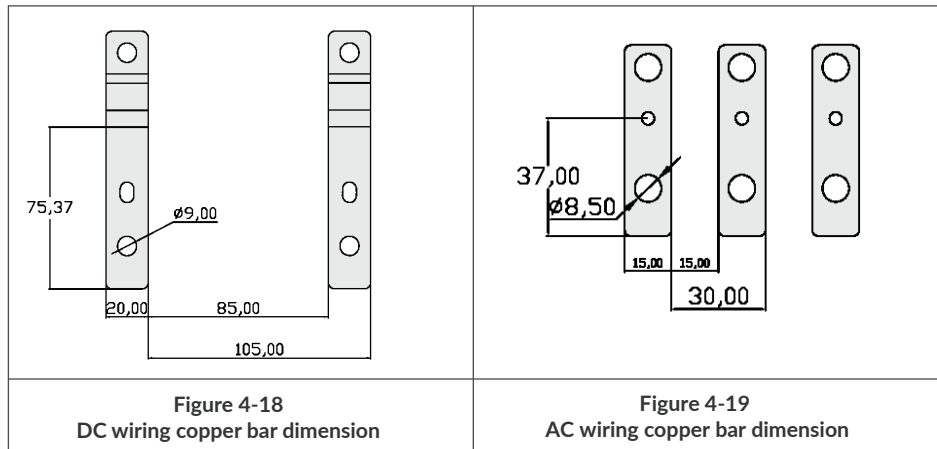

Figure 4-17 PCS wiring copper bars designation with STS module

**Table 19 PCS wiring copper bars description**

Position	Designation	Description
1	PV +	PV positive port, dimension is shown as below.
2	PV -	PV negative port
3	Battery +	Battery positive port
4	Battery -	Battery negative port
5	A (Load)	Phase A, dimension is shown as below
6	B (Load)	Phase B
7	C (Load)	Phase C
8	A (Grid)	Phase A
9	B (Grid)	Phase B
10	C (Grid)	Phase C
11	N	Phase N
12	Grounding	



**4.4.3. AC Auxiliary Power-Wiring**

Please connect the AC auxiliary power cable to each HV900105 with the Grid/GEN L phase (anyone of L1, L2 and L3 phase) and N pole of PCS as the following Figure 4-20 shows.

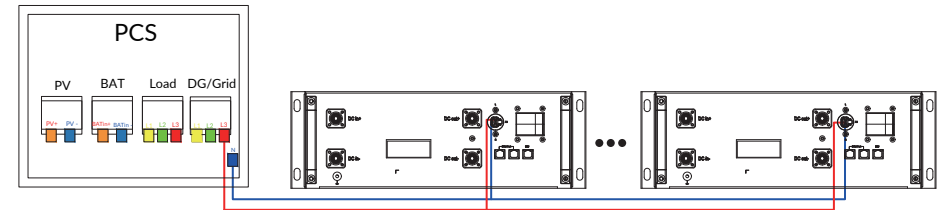

**Figure 4-20 AC Auxiliary Power Cable Connection**



**NOCE:**  
The auxiliary power cable bond must be placed above the AC power cable bond. After this please tighten the screw.

**4.4.4. System grounding**

The grounding of power modules/PCS connection with the rack should go through hangers on the module.

As for rack grounding, the rack bottom is installed with grounded copper bars. The cable diameter can be referred to the following table.



**WARNING**

Notice that the AC output neutral is not connected to ground.

**Table 20 Grounding PE cable description**

Rated power	Copper PE cable section recommendation (mm <sup>2</sup> )
50kW	≥16
100kW	≥25



**WARNING**

Rack and modules need to be grounded reliably! The grounding resistance should be less than 4Ω.

### 4.4.5. PV Side-Wiring

- A. Use a multimeter to measure the voltage of PV port, and ensure that the voltage is within input voltage range of PCS.
- B. Disconnect PV switch. Wiring can be conducted after confirming that there is no voltage between positive and negative poles of PV input.
- C. Connect the positive pole of storage battery to "DC+" of DC input of DC switch.
- D. Connect the negative pole of storage battery to "DC-" of DC input of DC switch.
- E. Confirm wiring firmness.

Table 21 DC cable description

Rated power	Copper DC cable section recommendation (mm <sup>2</sup> )
50kW	≥35
100kW	≥95

The PV connection is shown in Figure 4-21

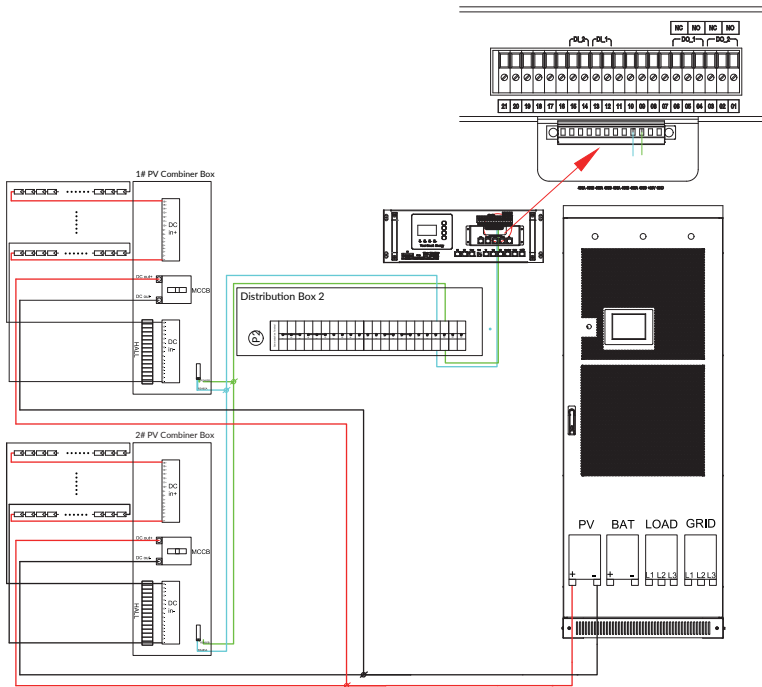

Figure 4-21 Connect the power cable of the PV , With Combiner box

- A. Use a multimeter to measure the PV port voltage and ensure that the voltage is within the input voltage range of the PCS.
- B. Turn off the PV switch on PCS. Use a multimeter to measure and confirm that there is no voltage between the positive and negative terminals of the PV input. Then connect cables.
- C. Connect PV positive pole to "DC+" of PV side DC switch on PCS.
- D. Connect PV negative pole to "DC-" of PV side DC switch on PCS.

**NOTE:**  
 There are numbers on the PV combiner box, it have to one-to-one correspondence. For example, "1+" corresponds to "1-", "2+" corresponds to "2-", and so on.

- E. Connect another PV Combiner box and repeat steps A), B), C).

**NOTE:**  
 Only 1 PV combiner box can communication with Top BMU, and all boxed can connect in parallel.

### 4.4.6. AC Side-Wiring

- A. Ensure that the phase consequence of wires should be a positive consequence.
- B. Disconnect AC output distribution switch in PCS.
- C. Use a multimeter to measure and ensure that the cables connected to the terminals are electrically neutral.
- D. In on-grid mode, A(L1)/B(L2)/C(L3) phases of AC output distribution switch of utility grid and PE are respectively connected to A(L1)/B(L2)/C(L3) phases of utility grid and PE.
- E. In off-grid mode, A(L1)/B(L2)/C(L3) phases of AC output distribution switch of PCS and PE are respectively connected to A(L1)/B(L2)/C(L3) phases of generator AC output and PE.
- F. Confirm wiring firmness.



Table 22 AC cable description

Rated power	Copper AC cable section recommendation (mm <sup>2</sup> )
50kW	≥25(Load port); ≥50(Grid port);
100kW	≥50(Load port); ≥95(Grid port);

**WARNING**

Ensure that there is no voltage at connection points during wiring.

**NOTICE:**

All wires are connected to the wiring terminals externally from the wiring holes at the bottom of PCS. After wiring, fireproofing mud should be used to seal the wiring holes.

Please refer to the following diagram to connect power cables.

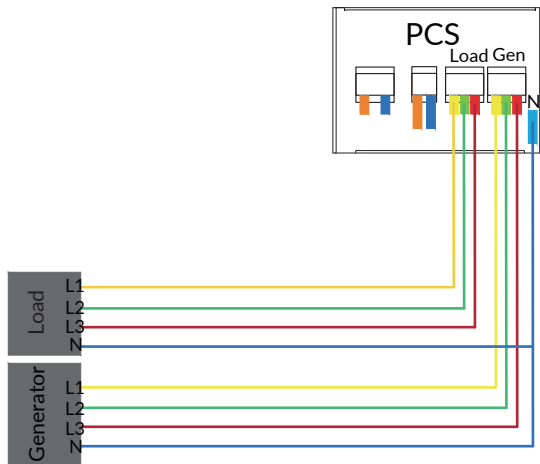

Figure 4-22 AC-Side wiring diagram, off-grid mode

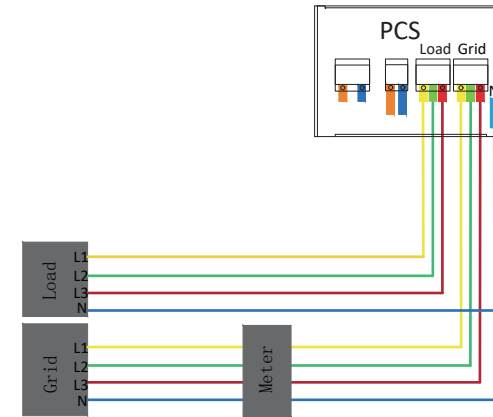

Figure 4-23 AC-Side wiring diagram, on-grid mode

4.4.7. Meter Wiring(On-grid mode)

Please refer to the following diagram to connect the CT meter.

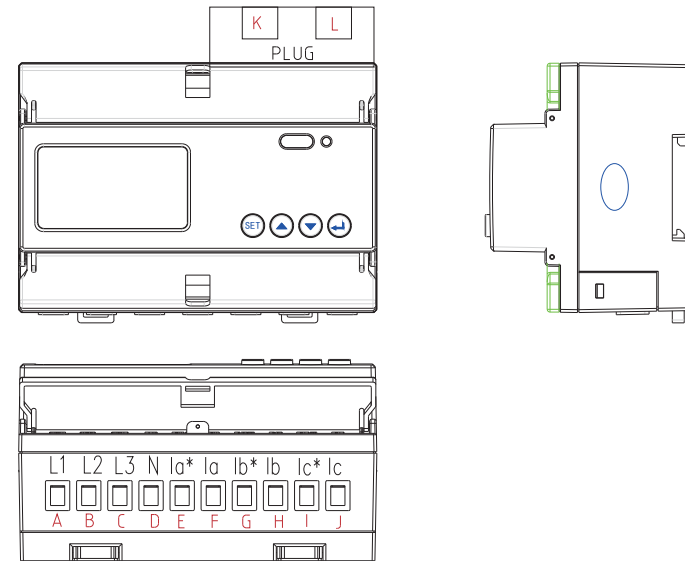

Figure 4-24 Appearance of the meter

Table 23 Ports Description

Object	Name	Description
A	Power port 1	Connect to L1
B	Power port 2	Connect to L2
C	Power port 3	Connect to L3
D	Power port N	Connect to N
E	CT1 sampling cable wiring port Ia*	Connect to S1 of CT1
F	CT1 sampling cable wiring port Ia	Connect to S2 of CT1
G	CT2 sampling cable wiring port Ib*	Connect to S1 of CT2
H	CT2 sampling cable wiring port Ib	Connect to S2 of CT2
I	CT3 sampling cable wiring port Ic*	Connect to S1 of CT3
J	CT3 sampling cable wiring port Ic	Connect to S2 of CT3
K	Meter communication port 1	Connect to EMS or other meters through network cable to realize communication between devices.
L	Meter communication port 2	Connect to EMS or other meters through network cable to realize communication between devices.

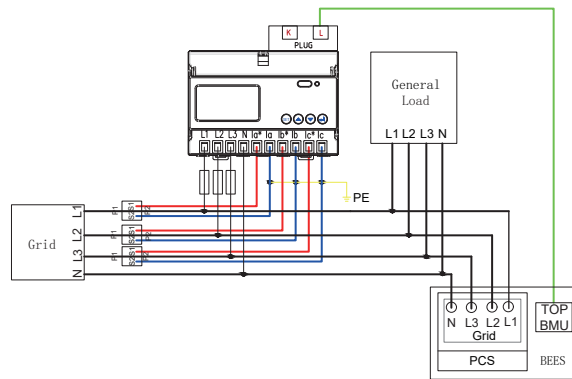

Figure 4-25 Meter wiring diagram (DC mode)

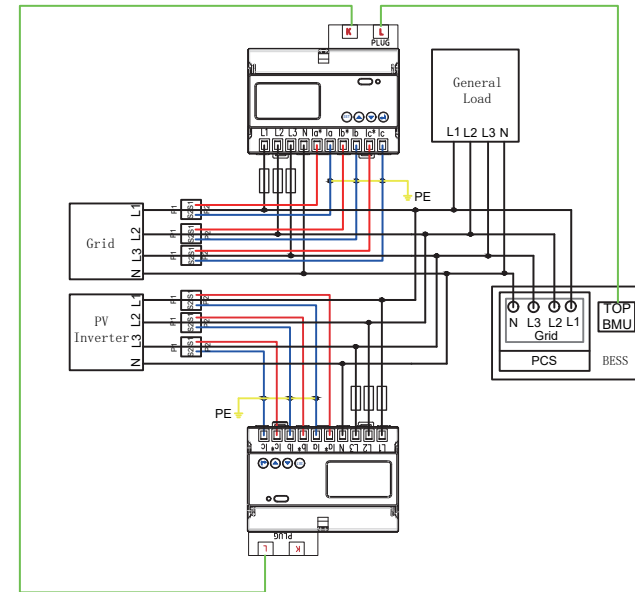

Figure 4-26 Meter wiring diagram (AC / Hybrid mode)

The meter communication cable should be connected to TOP BMU COM 6.

4.4.8. Connect the communication cable for the generator

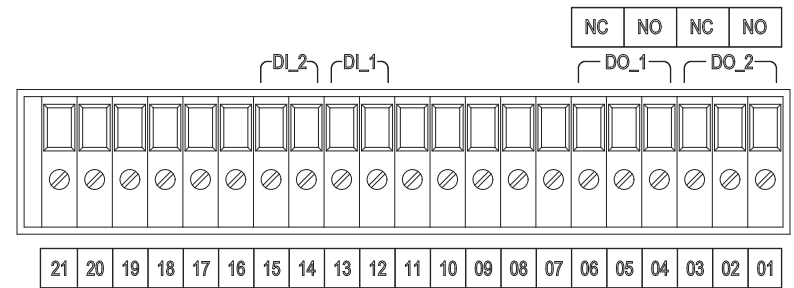

Figure 4-27 Dry contact of TOP BMU

- A. Connect DO\_2 (port 1 & 2) to the dry contact of the generator, because port 2 and 3 are normally closed but 1 and 2 are normally open.
- B. Please connect the generator controller to dry contact as the Figure 4-28 shows.

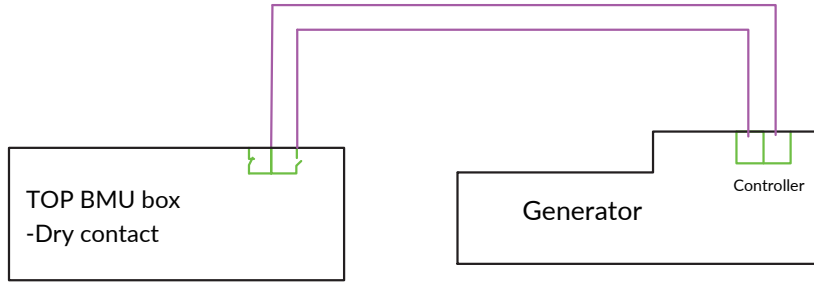

Figure 4-28 Connecting the communication cable for generator

#### 4.4.9. Sealing Measures



**NOTE :** When the wiring is completed, use fireproof mud or other non-inflammable and well-sealed materials to block the inlet.

## 05 Start-up and Operation

Please refer to the Operation Manual for details.

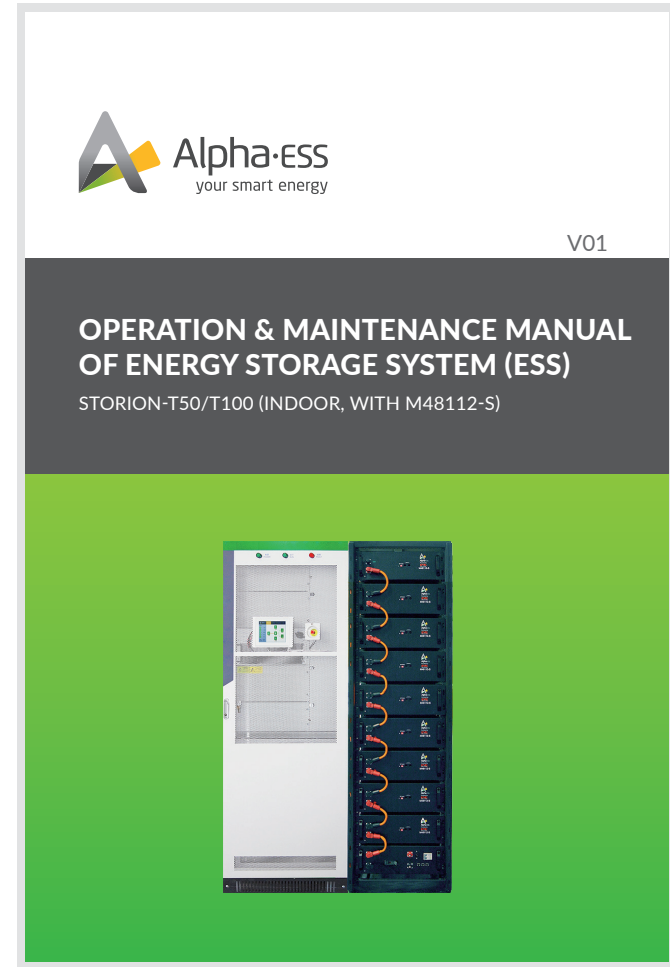

06 PCS Dry Contact Enable

When the system is running normally and the system starts commission, remove the communication shorting screw on the PCS (terminal 1, 2). For the detailed commission steps, refer to the commission list.

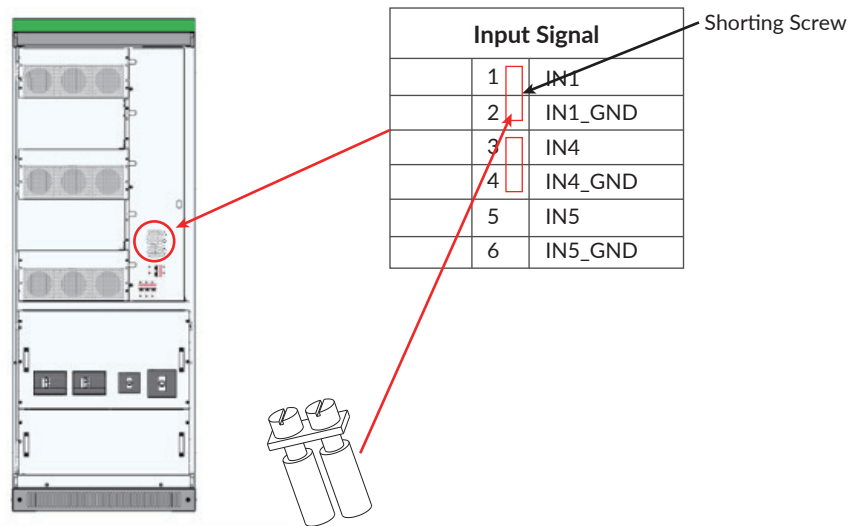

Figure 6-1 Remove the communication shorting screw



**NOTE :** Don't throw away the communication shorting screw in case they need to be reused.

07 Contact

If you have technical problems with our products, please contact us. Contact information is under the IMPRINT catalog at the beginning of this manual. Please provide the following information to help you with the necessary assistance:

- A. Equipment model
- B. Serial number
- C. Battery type and number, or PV modules number and string type
- D. Communication type
- E. Firmware version
- F. Error number and error message